

ITEM NO.	PART NUMBER	DESCRIPTION	Default/ QTY.
1	01-200-0002	SuspClevLower	1
2	01-200-0003	SuspClevLowerWasher	2
3	01-200-0014	SuspClevLowerSpacer	2
4	HX-SHCS 0.3750-16-D-N-16x1.75x1.75-N		1
5	HNUT 0.3750-16-D-N		1
6	HX-SHCS 0.375-16x1.5x1.5-N		2
7	Preferred Narrow FW 0.375		2

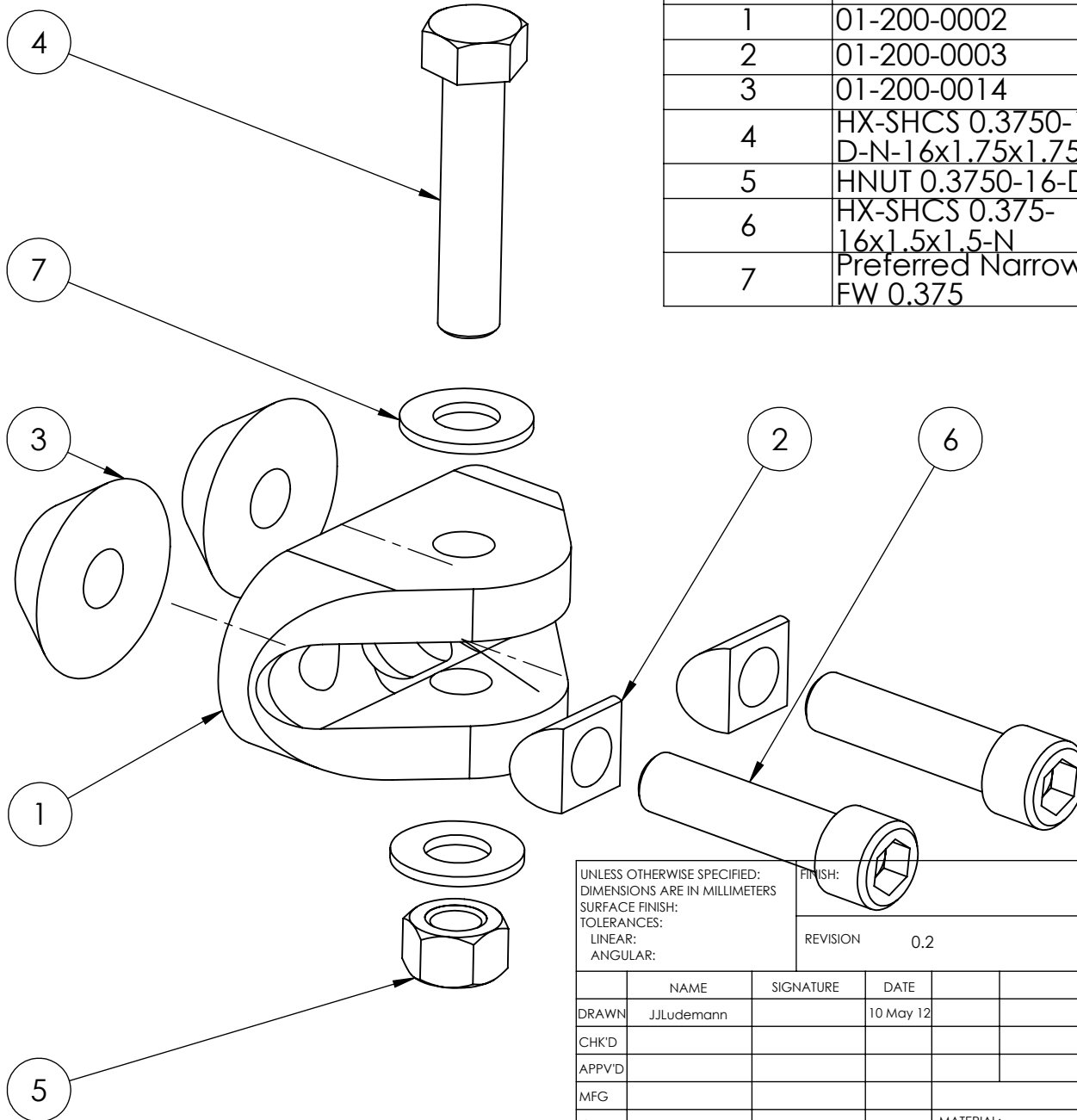

UNLESS OTHERWISE SPECIFIED: DIMENSIONS ARE IN MILLIMETERS SURFACE FINISH: TOLERANCES: LINEAR: ANGULAR:		FINISH:	DEBUR AND BREAK SHARP EDGES
		REVISION 0.2	
	NAME	SIGNATURE	DATE
DRAWN	JJLudemann		10 May 12
CHK'D			
APPV'D			
MFG			
Q.A			
			MATERIAL:
			WEIGHT:



TITLE:	
SuspClevLowerAssy	
DWG NO.	01-200-0007
	A4
SCALE:1:1	SHEET 1 OF 1